



Spare Parts List ANTARES

M300V.2025 SM 47–583–52

M300V.2530 SM 47–583–53

M300V.3035 SM 47–583–54

M300V.30 SR 41–583–41

Issue 09/2024

Table description	Issue	n. of pages
Overall view	09/2024	1
C.h. return–flow group and d.h.w. heat exchanger	09/2024	1
C.h. flow and return groups	09/2024	1
Pump and main circuit assembly – combi	09/2024	1
Pump and main circuit assembly – system	09/2024	1
Gas assembly	09/2024	1
Valves and connection pipes combi	09/2024	1
Valves and connection pipes system	09/2024	1
Control panel and ignition device	09/2024	1
Wiring combi	09/2024	1
Wiring system	09/2024	1
Fan, combustion chamber and case panels	09/2024	1
List of parts combi	09/2024	5
List of parts system	09/2024	4

M300V.2025 SM
M300V.2530 SM
M300V.3035 SM
M300V.30 SR

47-583-52
47-583-53
47-583-54
41-583-41

Overall view

DATA BADGE: inner side of left case panel

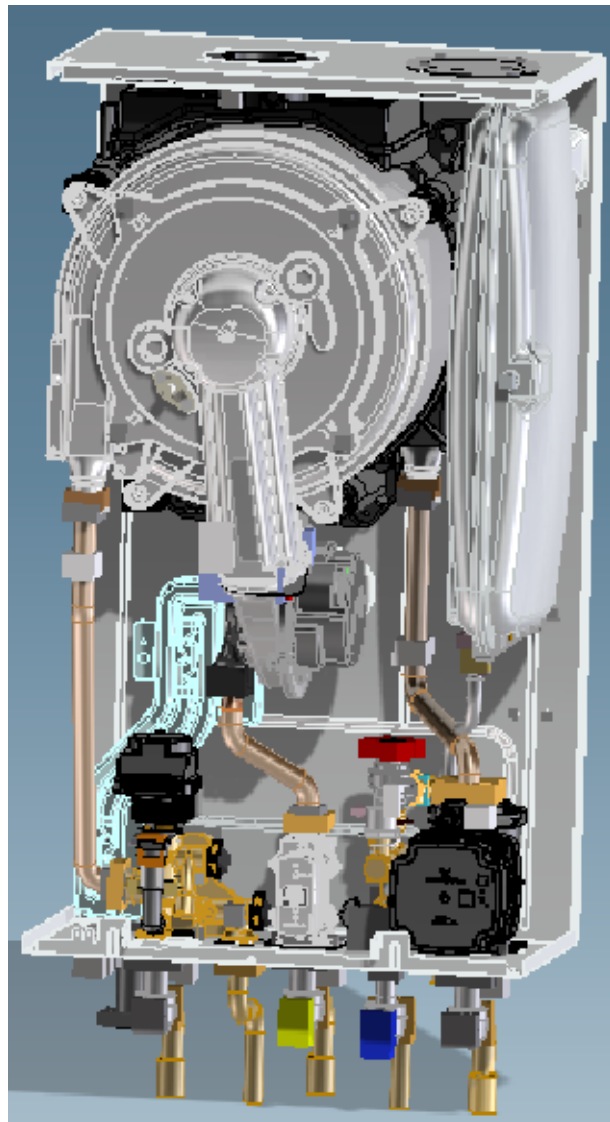

M300V.2025 SM
M300V.2530 SM
M300V.3035 SM

47-583-52
47-583-53
47-583-54

C.h. flow-return group and d.h.w. heat exchanger

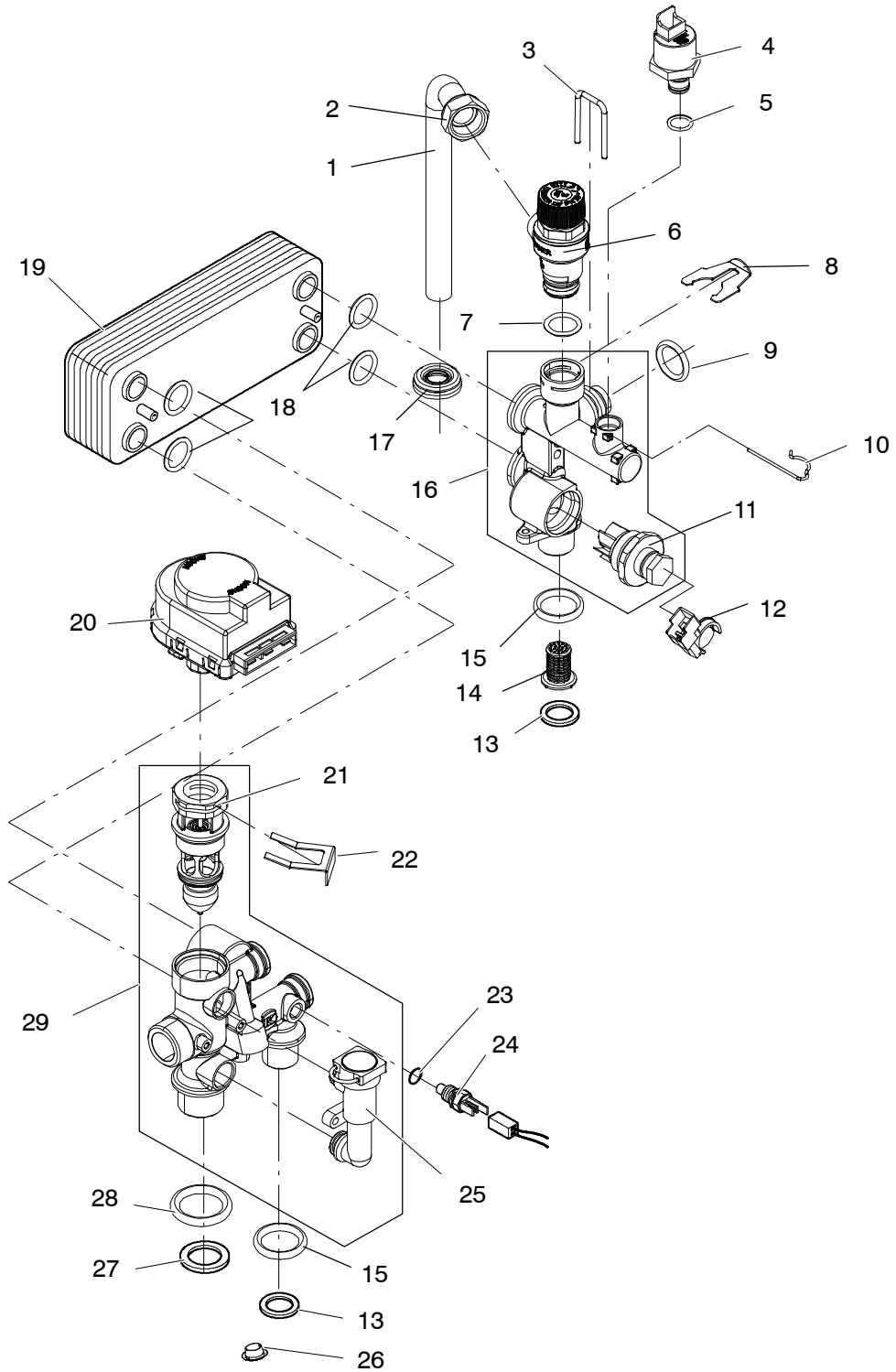

C.h. flow and return groups

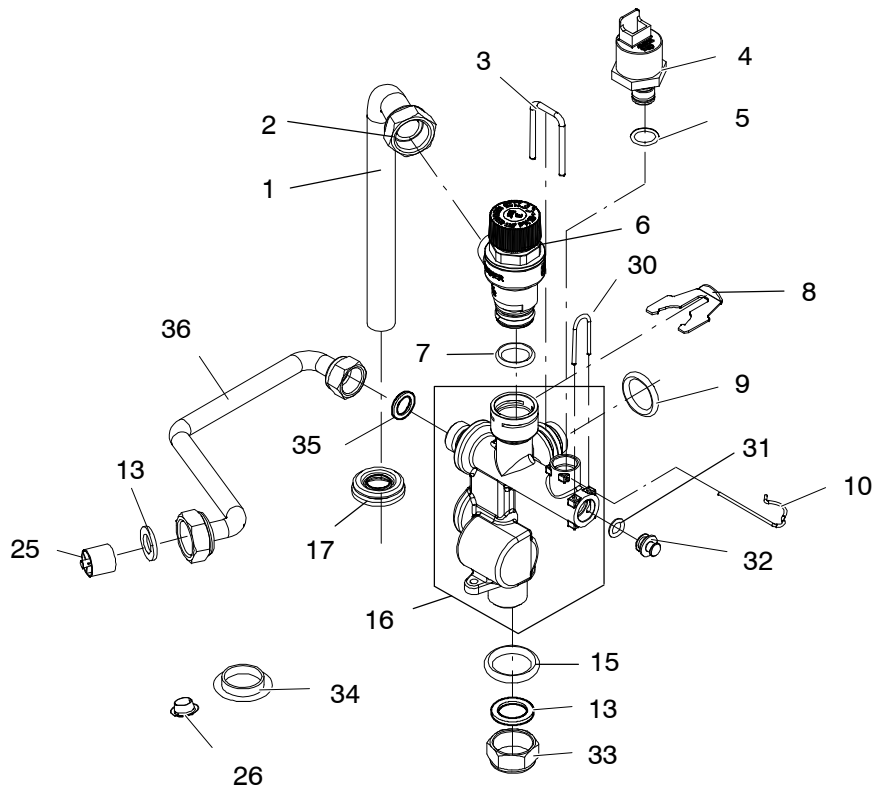

M300V.2025 SM
M300V.2530 SM
M300V.3035 SM

47-583-52
47-583-53
47-583-54

Pump and main circuit assembly

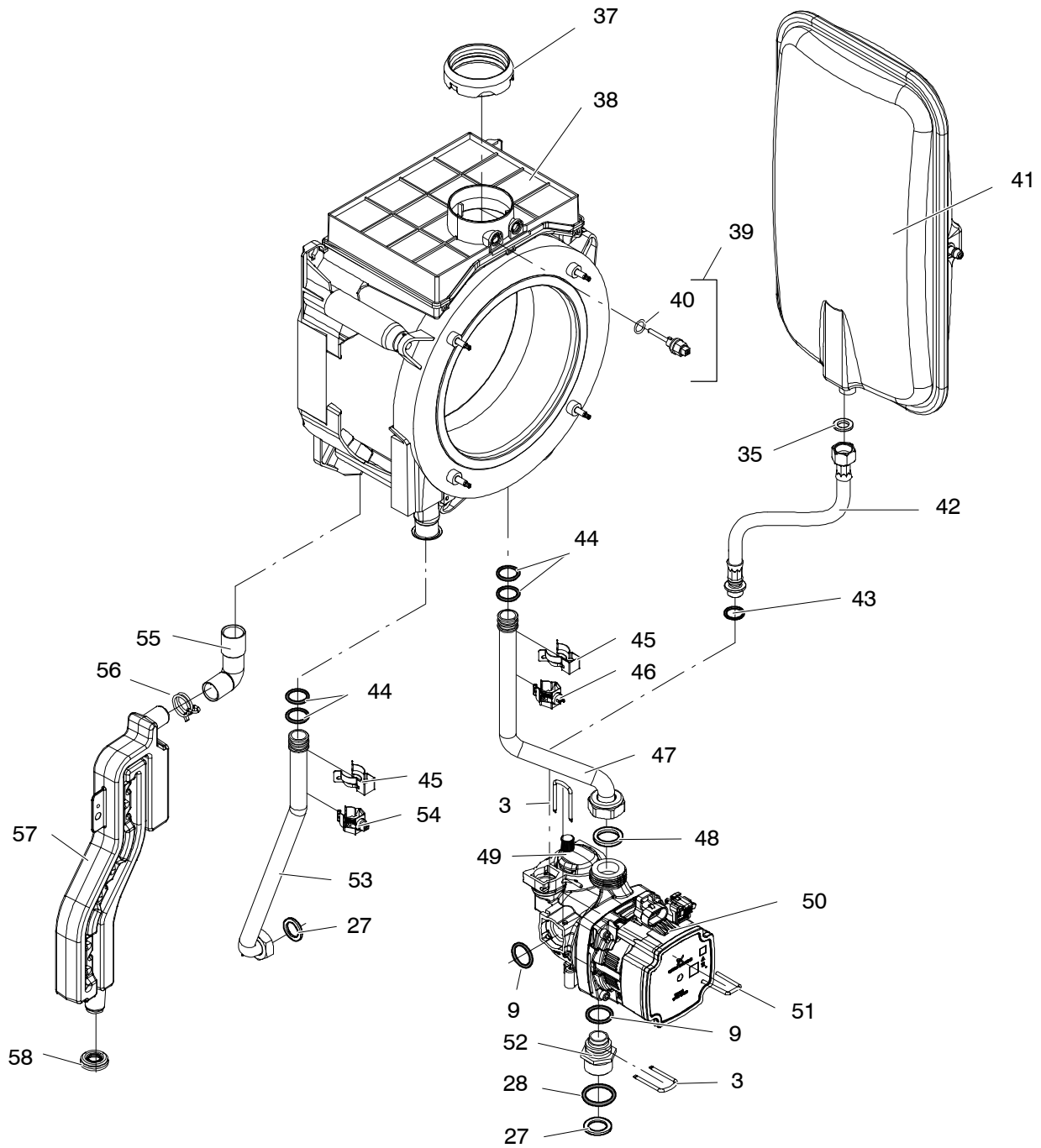

Pump and main circuit assembly

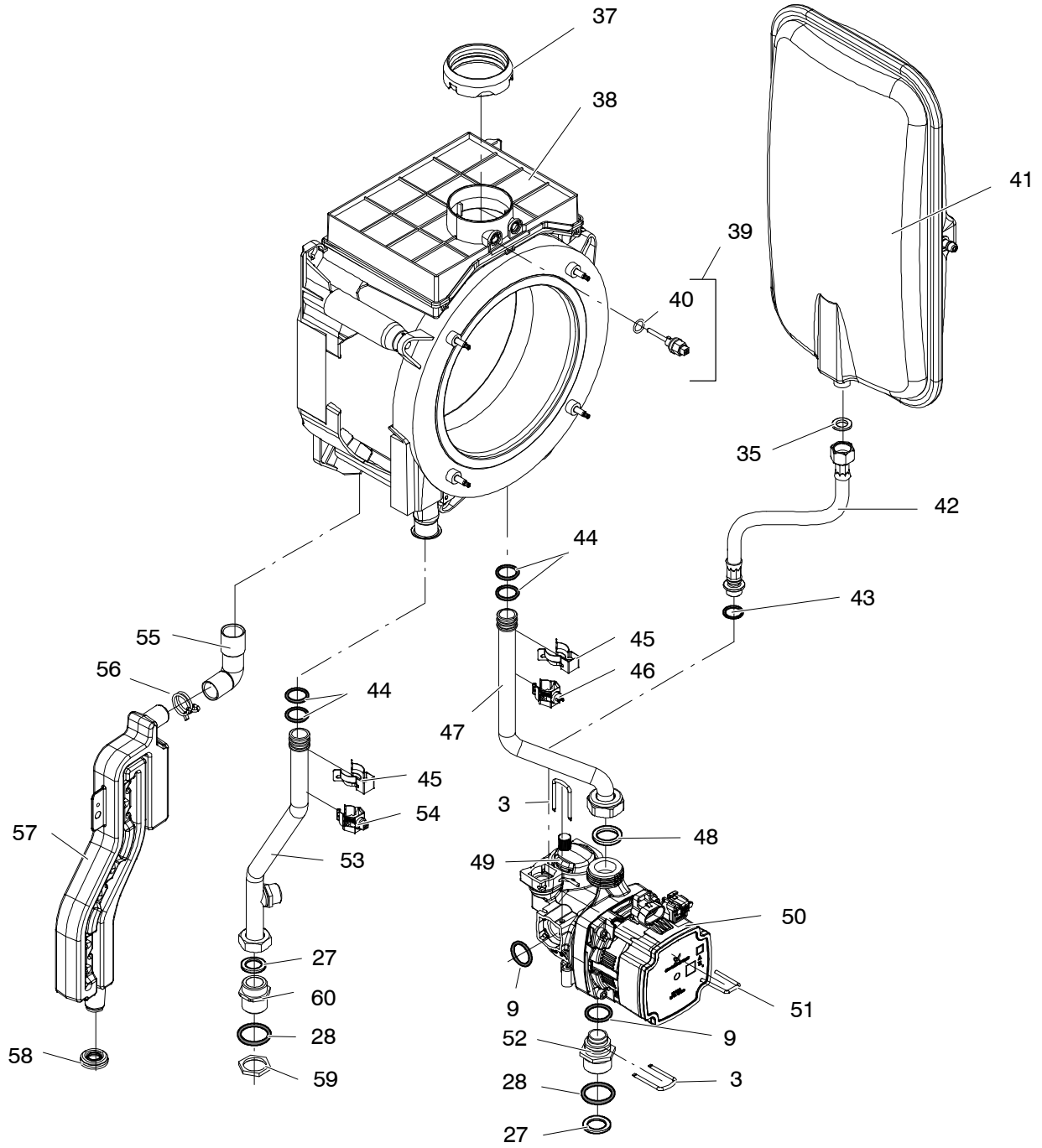

M300V.2025 SM
M300V.2530 SM
M300V.3035 SM
M300V.30 SR

47-583-52
47-583-53
47-583-54
41-583-41

Gas assembly

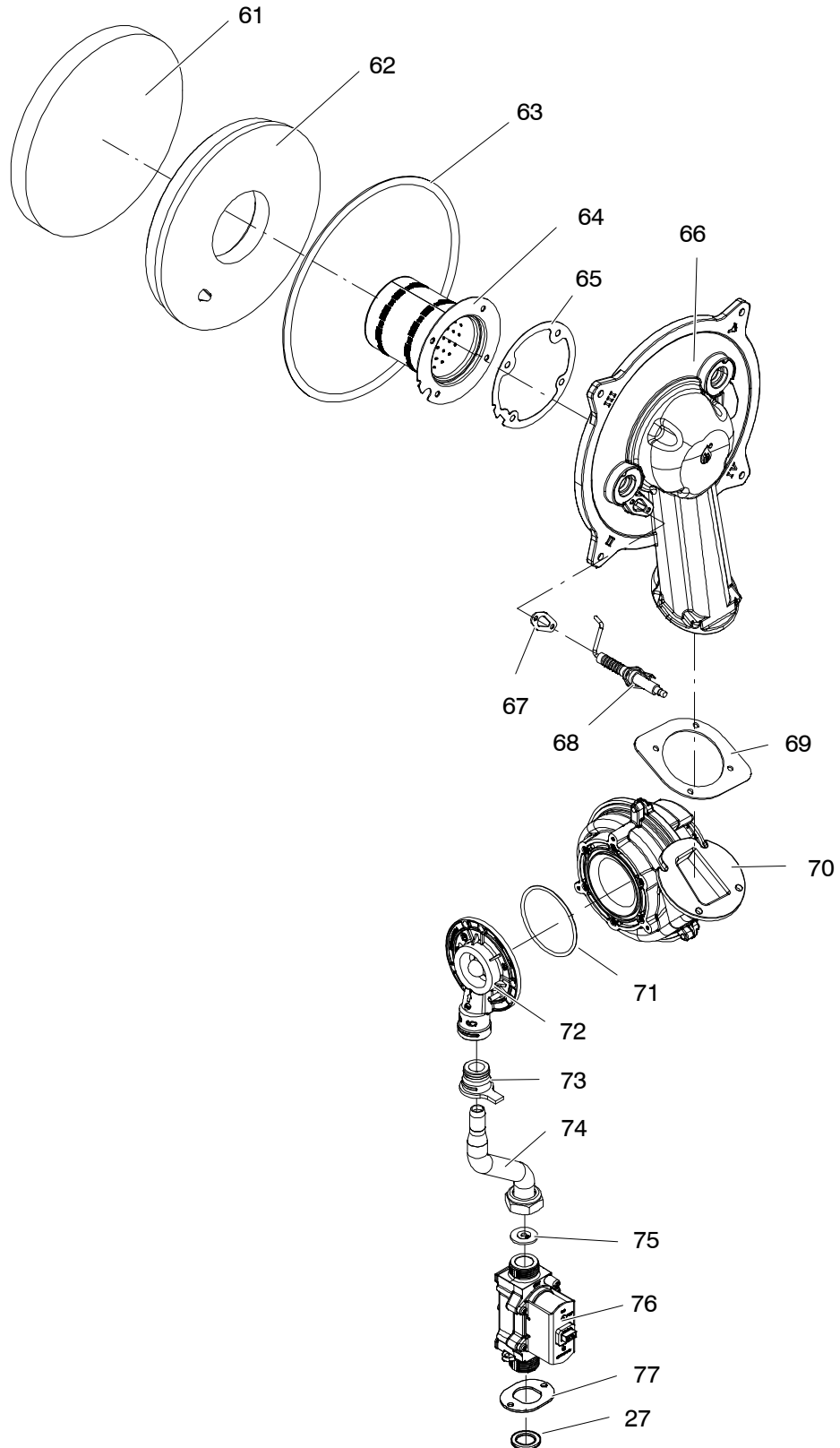

M300V.2025 SM
M300V.2530 SM
M300V.3035 SM

47-583-52
47-583-53
47-583-54

Valves and connection pipes

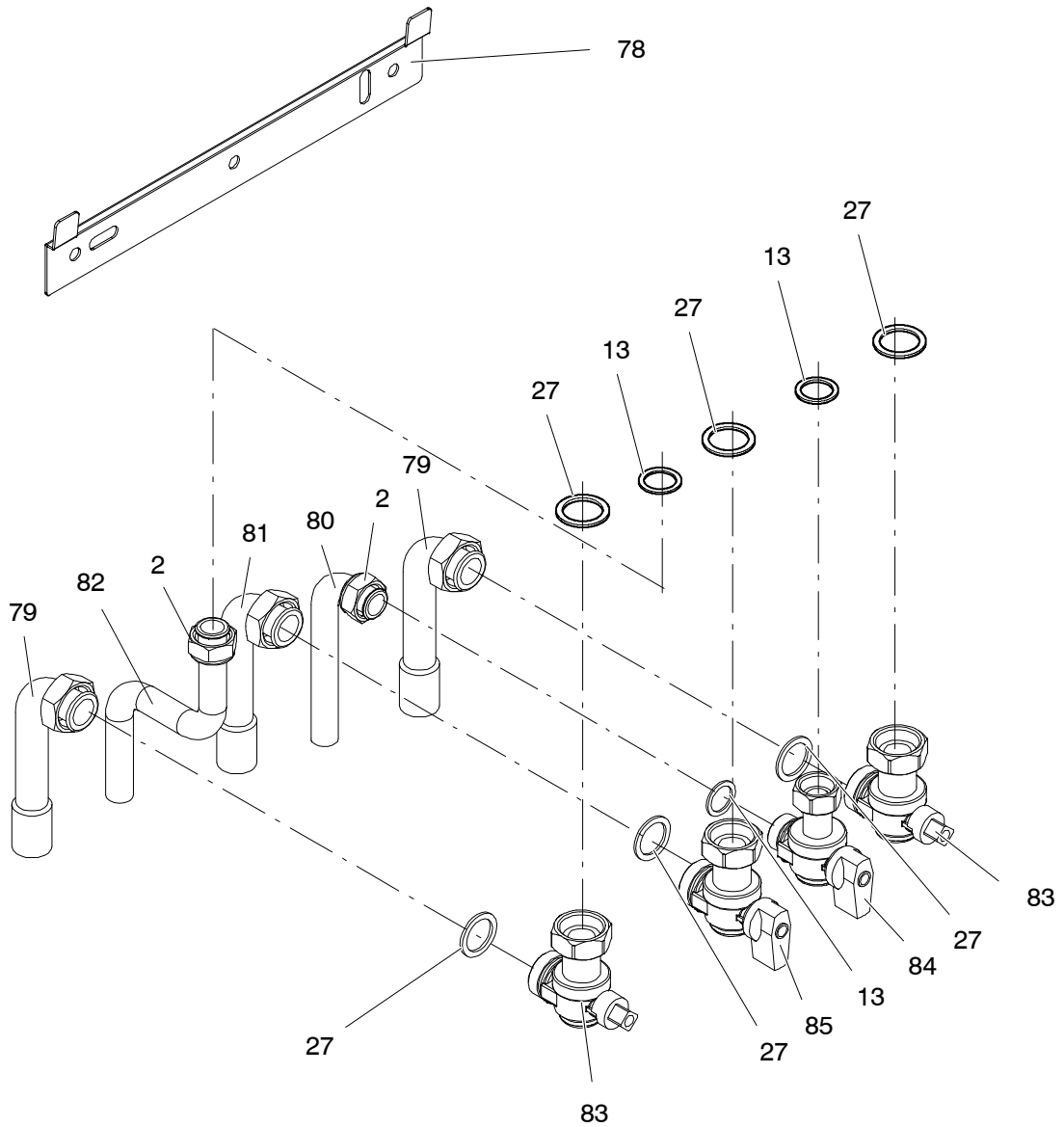

Valves and connection pipes

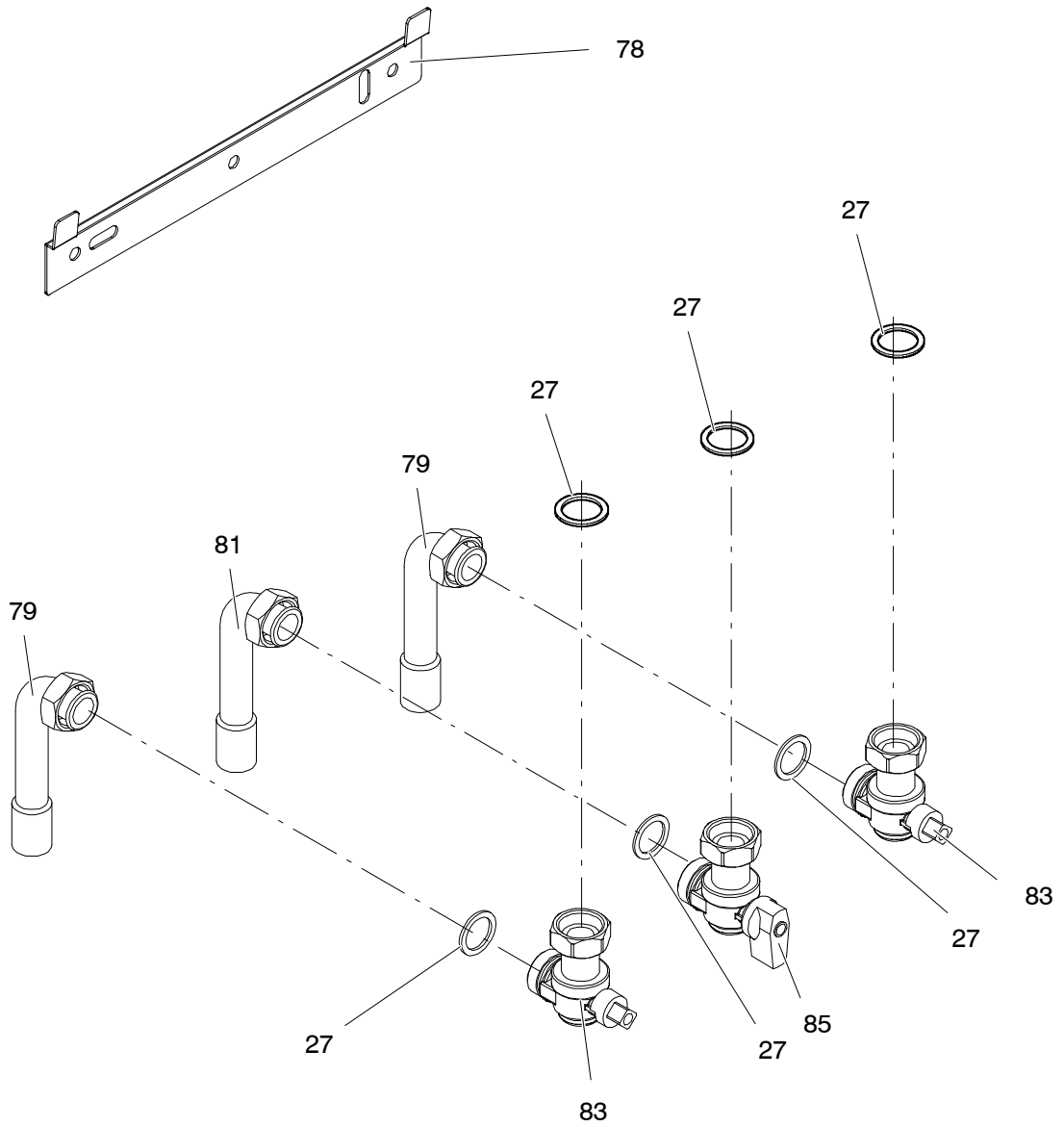

M300V.2025 SM
M300V.2530 SM
M300V.3035 SM
M300V.30 SR

47-583-52
47-583-53
47-583-54
41-583-41

Control panel and ignition device

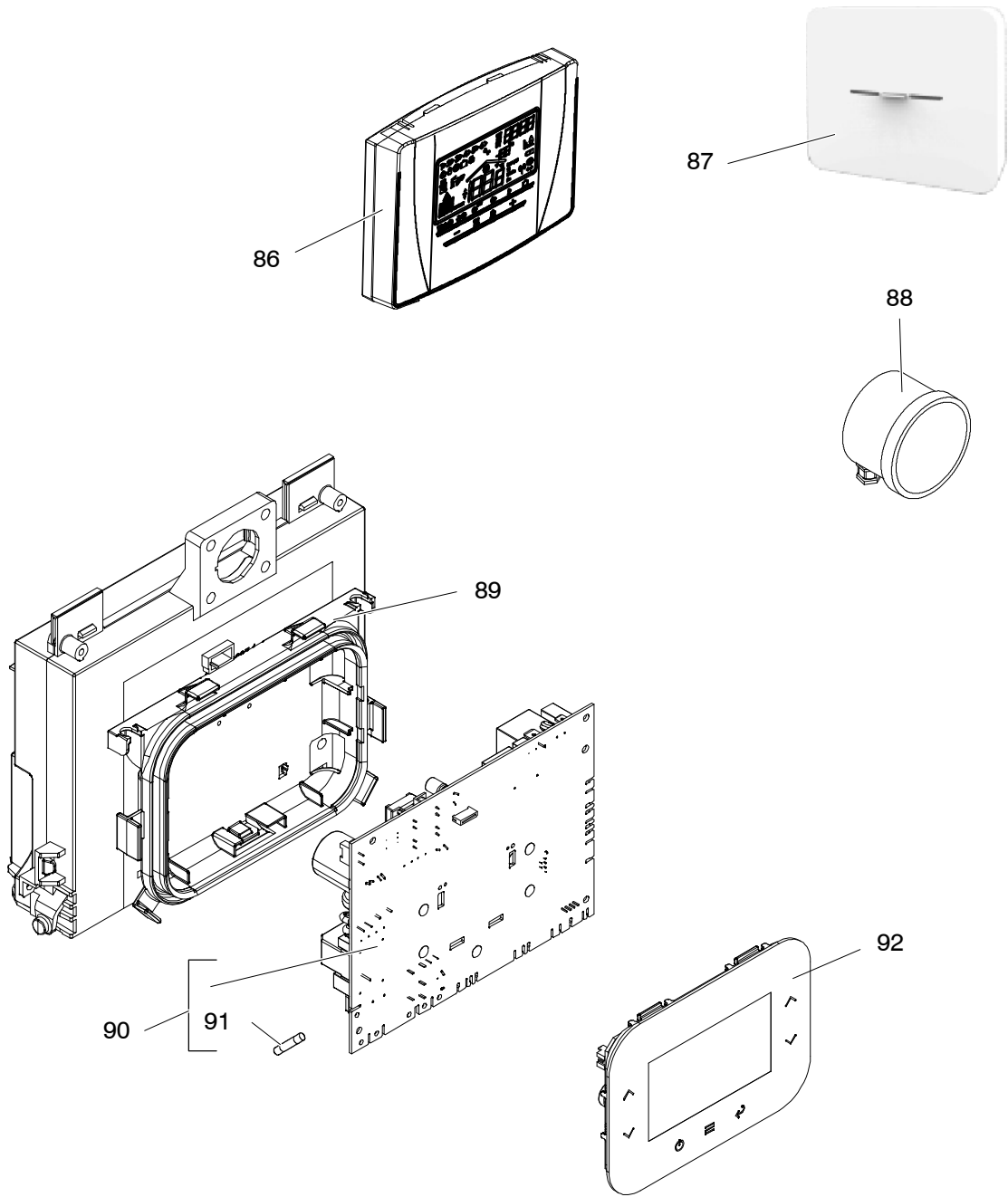

M300V.2025 SM
M300V.2530 SM
M300V.3035 SM

47-583-52
47-583-53
47-583-54

Wiring system

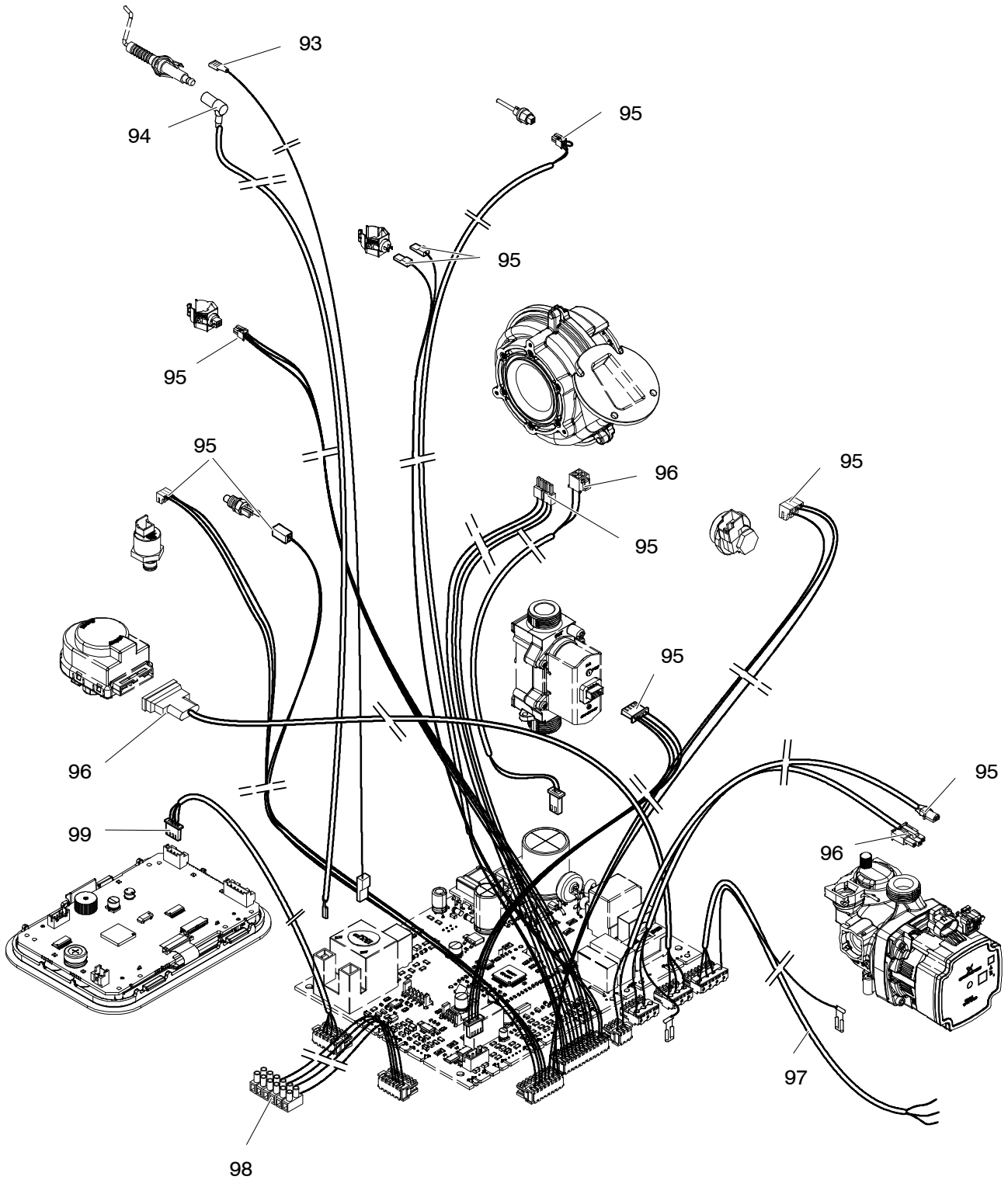

Wiring system

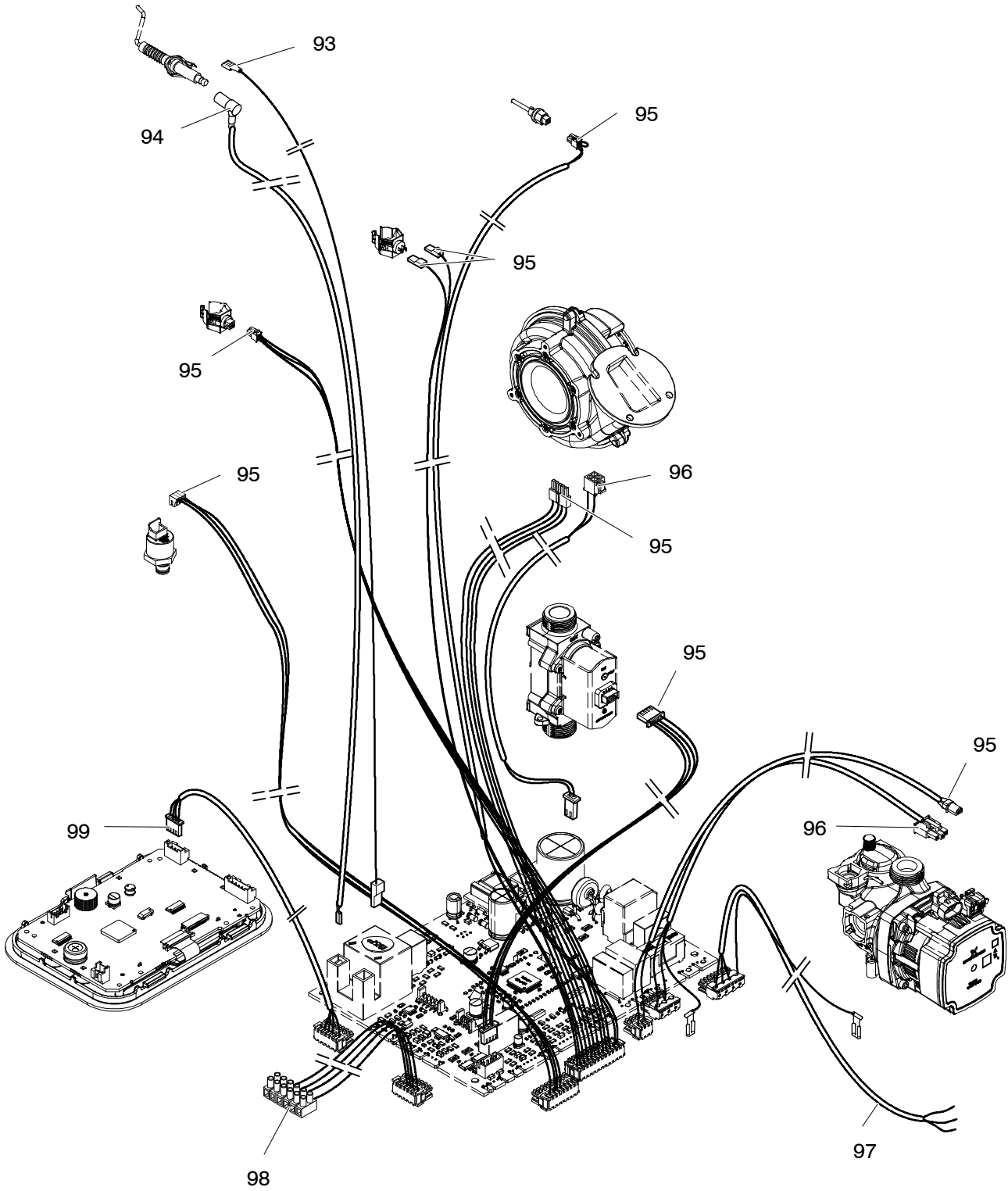

M300V.2025 SM
M300V.2530 SM
M300V.3035 SM
M300V.30 SR

47-583-52
47-583-53
47-583-54
41-583-41

Sealed chamber and case panels

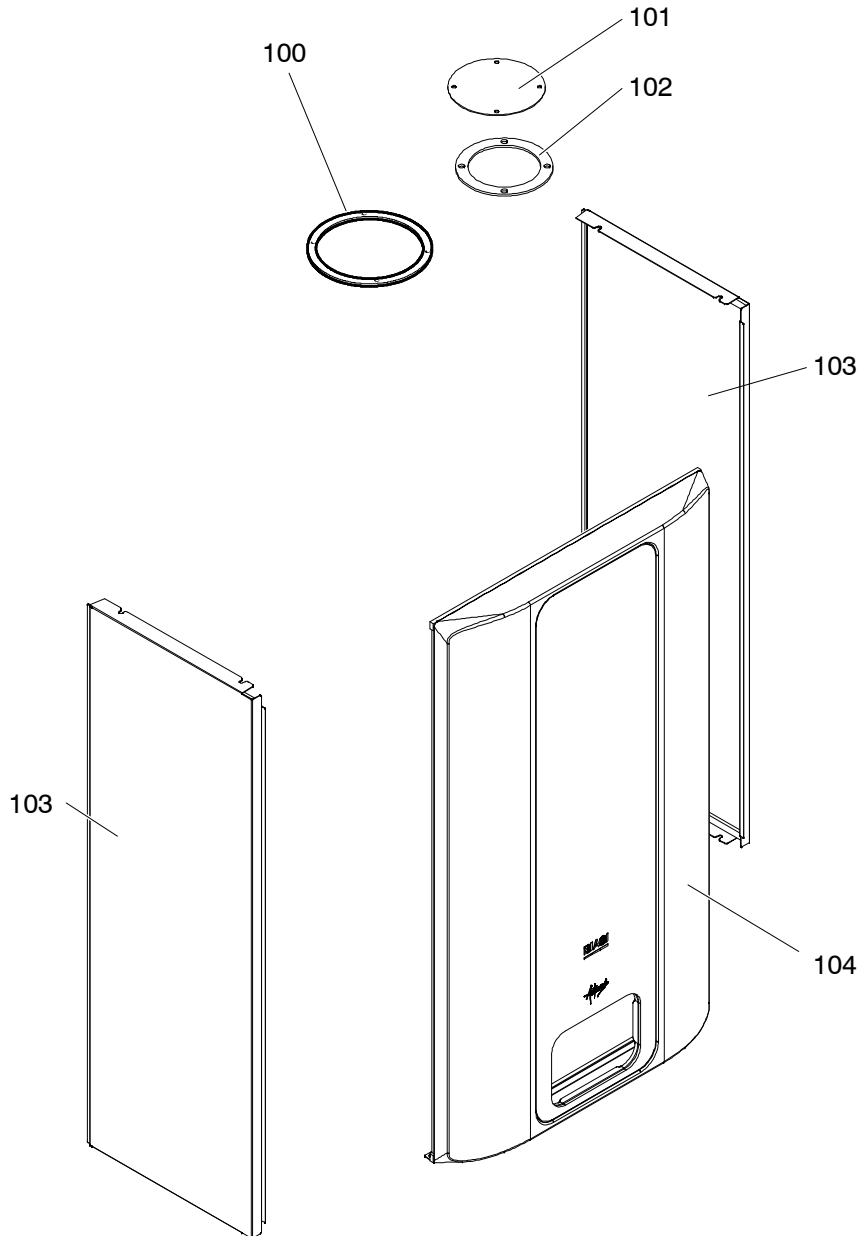

DRAFT BRITISH GAS PART LIST

Date _____ of _____ 5
 Sheet 1 of 5
 Manufacturer Biasi SpA – Italy
 Appliance(s) M300V.2025 SM M300V.2530 SM M300V.3035 SM
 GC Appliance Number(s) 47 –583 –52 47 –583 –53 47 –583 –54
 Contract Name _____
 Telephone Number _____

(a)	(b)	(c)	(d)	(e)	(f)	(g)	(h)	(i)	(j)	(k)
Key no.	GC Part Number	Description	No. Off	Makers part number which have a CG number	Maker's old part number which have since been changed	Maker's new part number which DO NOT have a GC number	M B F	Original Supplier	Original Supplier part number	Retail price excl. VAT
		Position of data badge: frame, inner lower side								
		Instructions booklets set	1			BI1913 557	M			
1		Safety valve connection pipe	1			BI1801 100	M			
2	E01 – 226	Nut 1/2"	1	BI1004 101			M			
3		Fork P21,5	1			BI2011 106	M			
4		Primary circuit pressure transducer	1			BI1592 115	M			
5	H74 – 540	O – ring gasket 1,90x8,90	1	BI1351 113			M			
6		Safety valve 3 bar	1			BI1621 101	B		3 bar	
7		O – ring gasket 2,62x15,88	1			KI1042 110	M			
8	H20 – 987	Safety valve connection fork	1	BI1262 116			M			
9		O – ring gasket 3,53x18,64	2			BI1621 102	M			
10		Fork	1			BI1592 113	M			
11		Magnetic flow switch	1			BI1621 104	M			
12		D.h.w. flow switch	1			BI1621 112				
13	169 – 141	Flat gasket 1/2"	3	BI1001 106			M			
14		Filter	1			BI1621 111	M			
15		O – ring gasket 2,62x17,86	2			KI1042 118	M			
16		Return group kit – M300V.2025 SM	1			BI1801 112	M			
16 A		Return group kit – M300V.2530 SM, M300V.3035 SM	1			BI1801 101	M			
17		Grommet	2			BI1301 109	M			
18	169 – 060	O – ring gasket 18,64x3,53	4	KI1043 144			M			
19	E01 – 204	Exchanger DHW – M300V.2025 SM	1	BI1001 101			M			
19 A	E01 – 205	Exchanger DHW – M300V.2530 SM, M300V.3035 SM	1	BI1001 102			M			
20		Diverter valve actuator	1			BI1801 102	M			
21		Diverter valve kit	1			BI1801 103	M			

CONTINUATION SHEET

Sheet 2 of 5

Appliance number(s) 47-583-52 47-583-53 47-583-54

(a) Key no.	(b) GC Part Number	(c) Description	(d) No. Off	(e) Makers part number which have a CG number	(f) Maker's old part number which have since been changed	(g) Maker's new part number which DO NOT have a GC number	(h) M B F	(i) Original Supplier	(j) Original Supplier part number	(k) Retail price excl. VAT
22		Diverter valve actuator fixing spring	1			BI1101 101	M			
23	H23-733	O-ring gasket 1,78x9,25	1	KI1001 128			M			
24	164-026	Temperature probe NTC d.h.w.	1	BI1001 117			M			
25		By-pass kit	1			BI1801 119	M			
26		Plug	1			BI1801 108	M			
27	169-033	Flat gasket 3/4"	7	BI1001 108			M			
28		O-ring gasket 2,62X25,07	2			BI1801 107	M			
29		Flow group kit c.h.	1			BI1801 123	M			
35	H03-727	Flat gasket 3/8" O.D 15 mm, i.d. 8.5 mm	2	BI1202 105			M			
37	H74-575	Flue outlet gasket	1	BI1536 101			M			
38		Condensing heat exchanger - M300V.2025 SM	1			BI2002 100	M			
38 A		Condensing heat exchanger - M300V.2530 SM,	1			BI2112 100	M			
		M300V.3035 SM								
39		Flue temperature probe NTC and safety thermal fuse	1			BI1782 103	M			
40	H50-475	O-ring gasket 1,78x10,82	1	BI1181 110			M			
41		Expansion vessel	1			BI2262 108	B	WINKELMAN BUILDING+INDUSTRY	CRF8	
42		Expansion vessel connection pipe	1			BI2112 101	M			
43		O-ring gasket 3,53X12,29	1			BI1872 111	M			
44	H74-606	O-ring gasket 3x17	4	KI1003 114						
45	E83-108	Condensing heat exchanger connection clip	2	BI1172 101						
46		Return temperature probe	1			BI1442 106	M			
47		Condensing heat exchanger inlet pipe	1			BI2112 102	M			
48		Flat gasket 1"	1			BI1001 105	M			
49	H20-986	Automatic air purge valve	1	BI1212 107			M			
50		Pump	1			BI2262 106	M	GRUNDFOS	UPM4 15-75 CAOD	

CONTINUATION SHEET

Sheet 3 of 5

Appliance number(s) 47-583-52 47-583-53 47-583-54

(a) Key no.	(b) GC Part Number	(c) Description	(d) No. Off	(e) Makers part number which have a CG number	(f) Maker's old part number which have since been changed	(g) Maker's new part number which DO NOT have a GC number	(h) M B F	(i) Original Supplier	(j) Original Supplier part number	(k) Retail price excl. VAT
51		Expansion vessel connection fork	1			BI2262 107	M			
52		Threaded connection c.h.	1			BI2112 105	M			
53		Condensing heat exchanger outlet pipe- M300V.2025 SM	1			BI2112 107	M			
53 A		Condensing heat exchanger outlet piper	1			BI2112 106	M			
		M300V.2530 SM, M300V.3035 SM								
54		Flow temp. probe and overhear thermostat	1			BI1442 117	M			
55		Condensate discharge pipe	1			BI2112 108	M			
56	H20-972	Connection spring	1	BI1262 117			F			
57		Condensate trap	1			BI1782 107	M			
58	169-104	Grommet	1	BI1002 113			M			
61		Rear combustion chamber insulating panel	1			BI1563 100	M			
62		Front combustion chamber insulating panel	1			BI1663 100	M			
63		Combustion chamber lip gasket	1			BI1663 101	M			
64		Burner - M300V.2025 SM	1			BI1713 100	B			
64 A		Burner - M300V.2530 SM, M300V.3035 SM	1			BI1713 101	B			
65		Air-gas gasket	1			BI1663 102	M			
66		Flange burner goup	1			BI1663 103	M			
67	H58-678	Electrode gasket	2	BI1293 109			M			
68		Ignition/detection electrode	1			BI1713 107	M			
69		Fan gasket	1			BI1313 111	M			
70		Fan	1			BI1713 102	B	B&P	HPB1-00-01-011	
71		O-ring gasket 3X63 NBR	1			BI1253 114	M			
72		Air-box assembly - M300V.2025 SM	1			BI1713 103	M			
72 A		Air-box assembly - M300V.2530 SM, M300V.3035 SM	1			BI1713 104	M			
73		NBR gas joint	1			BI1563 108	M			

CONTINUATION SHEET

Sheet 4 of 5

Appliance number(s) 47-583-52 47-583-53 47-583-54

(a) Key no.	(b) GC Part Number	(c) Description	(d) No. Off	(e) Makers part number which have a CG number	(f) Maker's old part number which have since been changed	(g) Maker's new part number which DO NOT have a GC number	(h) M B F	(i) Original Supplier	(j) Original Supplier part number	(k) Retail price excl. VAT
74		Gas pipe – M300V.2025 SM	1			BI1713 105	M			
74 A		Gas pipe – M300V.2530 SM, M300V.3035 SM	1			BI1713 106	M			
75		Gas restrictor – M300V.2025 SM	1			BI1653 109	M			
75 A		Gas restrictor – M300V.2530 SM, M300V.3035 SM	1			BI1653 110	M			
76		Gas valve	1			BI1713 112	B	B&P SGV100	C1100022	
77		Gas valve gasket	1			BI1713 108	M			
78	E90-690	Wall mounting plate	1	BI1084 113			M			
79		Pipe 22 mm dia c.h.	2			BI1164 113	M			
80		Pipe 15 mm dia (bent) d.c.w.	1			BI1164 114	M			
81		Pipe 22 mm dia gas	1			BI1164 112	M			
82		Pipe 15 mm dia (bent) d.h.w.	1			BI1164 115	M			
83	E83-136	Tap 3/4" – c.h.	2	BI1084 105			B			
84	E83-137	Tap 1/2" – d.h.w.	2	BI1084 101			B			
85	E83-138	Tap 3/4" – gas	1	BI1084 100			B			
86		Remote control				BI2675 122	M			
87		Kt connects box WFC03.60	1			BI2675 123	M			
88		External temperature probe	1			BI1665 107	M			
89		Electronic p.c.b. box	1			BI2675 116	M			
90		Electronic control – ignition p.c.b.	1			BI2675 121	M			
91		Fuse 3,15 AF 250VAC 5x20	1			BI1295 108	B			
92		B&P SCP08 display board	1			BI2675 118	M			
93		Ignition/detection electrode earth cable	1			BI2685 114	M			
94		Ignition/detection electrode cable	1			BI2685 113	M			
95		Sensors cable	1			BI2685 145	M			
96		Electricity supply to 230V cable	1			BI2685 158	M			

DRAFT BRITISH GAS PART LIST

Date _____ of _____ 4
 Sheet 1 of 4
 Manufacturer Biasi SpA – Italy
 Appliance(s) M300V.30 SR
 GC Appliance Number(s) 41–583–41
 Contract Name _____
 Telephone Number _____

(a)	(b)	(c)	(d)	(e)	(f)	(g)	(h)	(i)	(j)	(k)
Key no.	GC Part Number	Description	No. Off	Makers part number which have a CG number	Maker's old part number which have since been changed	Maker's new part number which DO NOT have a GC number	M B F	Original Supplier	Original Supplier part number	Retail price excl. VAT
		Position of data badge: frame, inner lower side								
		Instructions booklets set	1			BI1913 558	M			
1		Safety valve connection pipe	1			BI1801 100	M			
2	E01–226	Nut 1/2"	1	BI1004 101			M			
3		Fork P21,5	1			BI2011 106	M			
4		Primary circuit pressure transducer	1			BI1592 115	M			
5	H74–540	O – ring gasket 1,90x8,90	1	BI1351 113			M			
6		Safety valve 3 bar	1			BI1621 101	B		3 bar	
7		O – ring gasket 2,62x15,88	1			KI1042 110	M			
8	H20–987	Safety valve connection fork	1	BI1262 116			M			
9		O – ring gasket 3,53x18,64	2			BI1621 102	M			
10		Fork	1			BI1592 113	M			
13	169–141	Flat gasket 1/2"	3	BI1001 106			M			
15		O – ring gasket 2,62x17,86	2			KI1042 118	M			
16		Return group kit	1			BI1831 100	M			
17		Grommet	2			BI1301 109	M			
25		By – pass kit	1			BI1831 111	M			
26		Plug	1			BI1801 108	M			
27	169–033	Flat gasket 3/4"	7	BI1001 108			M			
28		O – ring gasket 2,62X25,07	2			BI1801 107	M			
30		Fork P.10,5	1			BI1181 107	M			
31	E83–144	O – ring gasket 1,78 x 6,75	1	BI1475 119			M			
32		Return group plug	1			BI1512 109	M			
33		Plug 1/2"	1			BI1062 107	M			
34		Plug	1			BI1831 109	M			

CONTINUATION SHEET

Sheet 2 of 4
 Appliance number(s) 41 – 583 – 41

(a) Key no.	(b) GC Part Number	(c) Description	(d) No. Off	(e) Makers part number which have a CG number	(f) Maker's old part number which have since been changed	(g) Maker's new part number which DO NOT have a GC number	(h) M B F	(i) Original Supplier	(j) Original Supplier part number	(k) Retail price excl. VAT
35	H03–727	Flat gasket 3/8" O.D 15 mm, i.d. 8.5 mm	2	B11202 105			M			
36		By-pass pipe	1			B11831 108	M			
37	H74–575	Flue outlet gasket	1	B11536 101			M			
38	H58–660	Condensing heat exchanger – M300V.30 SR	1			B12112 100	M			
39		Flue temperature probe NTC and safety thermal fuse	1			B11782 103	M			
40	H50–475	O – ring gasket 1,78x10,82	1	B11181 110			M			
41		Expansion vessel	1			B12262 108	B	WINKELMAN BUILDING+INDUSTRY	CRF8	
42		Expansion vessel connection pipe	1			B12112 101	M			
43		O – ring gasket 3,53X12,29	1			B11872 111	M			
44	H74–606	O – ring gasket 3x17	4	K11003 114						
45	E83–108	Condensing heat exchanger connection clip	2	B11172 101						
46		Return temperature probe	1			B11442 106	M			
47		Condensing heat exchanger inlet pipe	1			B12112 102	M			
48		Flat gasket 1"	1			B11001 105	M			
49	H20–986	Automatic air purge valve	1	B11212 107			M			
50		Pump	1			B12262 106	M	GRUNDFOS	UPM4 15– 75 CAOD	
51		Expansion vessel connection fork	1			B12262 107	M			
52		Threaded connection c.h.	1			B12112 105	M			
53		Condensing heat exchanger outlet piper M300V.30 SR	1			B12112 110	M			
54		Flow temp. probe and overheat thermostat	1			B11442 117	M			
55		Condensate discharge pipe	1			B12112 108	M			
56	H20–972	Connection spring	1	B11262 117			F			
57		Condensate trap	1			B11782 107	M			
58	169–104	Grommet	1	B11002 113			M			
59		Lock – nut	1			K11005 106	M			

CONTINUATION SHEET

Sheet 3 of 4
 Appliance number(s) 41 – 583 – 41

(a) Key no.	(b) GC Part Number	(c) Description	(d) No. Off	(e) Makers part number which have a CG number	(f) Maker's old part number which have since been changed	(g) Maker's new part number which DO NOT have a GC number	(h) M B F	(i) Original Supplier	(j) Original Supplier part number	(k) Retail price excl. VAT
60		Threaded connection c.h.	1			BI2112 109	M			
61		Rear combustion chamber insulating panel	1			BI1563 100	M			
62		Front combustion chamber insulating panel	1			BI1663 100	M			
63		Combustion chamber lip gasket	1			BI1663 101	M			
64		Burner – M300V/30 SR	1			BI1713 101	B			
65		Air – gas gasket	1			BI1663 102	M			
66		Flange burner goup	1			BI1663 103	M			
67	H58 – 678	Electrode gasket	2	BI1293 109			M			
68		Ignition/detection electrode	1			BI1713 107	M			
69		Fan gasket	1			BI1313 111	M			
70		Fan	1			BI1713 102	B	B&P	HPB1 – 00 – 01 – 011	
71		O – ring gasket 3X63 NBR	1			BI1253 114	M			
72		Air – box assembly – M300V/30 SR	1			BI1713 104	M			
73		NBR gas joint	1			BI1563 108	M			
74		Gas pipe – M300V/30 SR	1			BI1713 106	M			
75		Gas restrictor – M300V/30 SR	1			BI1653 110	M			
76		Gas valve	1			BI1713 112	B	B&P SGV100	C1100022	
77		Gas valve gasket	1			BI1713 108	M			
78	E90 – 690	Wall mounting plate	1	BI1084 113			M			
79		Pipe 22 mm dia c.h.	2			BI1164 113	M			
81		Pipe 22 mm dia gas	1			BI1164 112	M			
83	E83 – 136	Tap 3/4" – c.h.	2	BI1084 105			B			
85	E83 – 138	Tap 3/4" – gas	1	BI1084 100			B			
86		Remote control				BI2675 122	M			
87		Kt connects box WFC03.60	1			BI2675 123	M			

